

Copying of this document and giving it to others and the use or communication of the contents thereof are forbidden without express authority. All rights reserved.

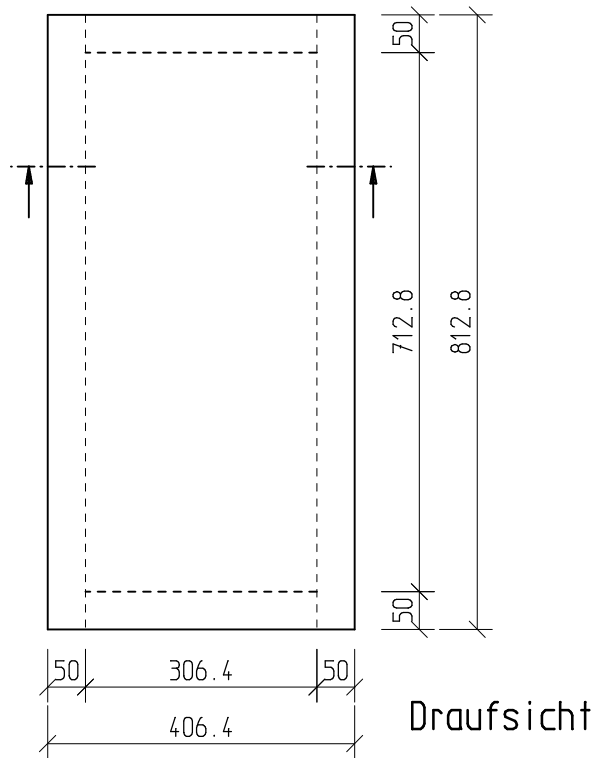
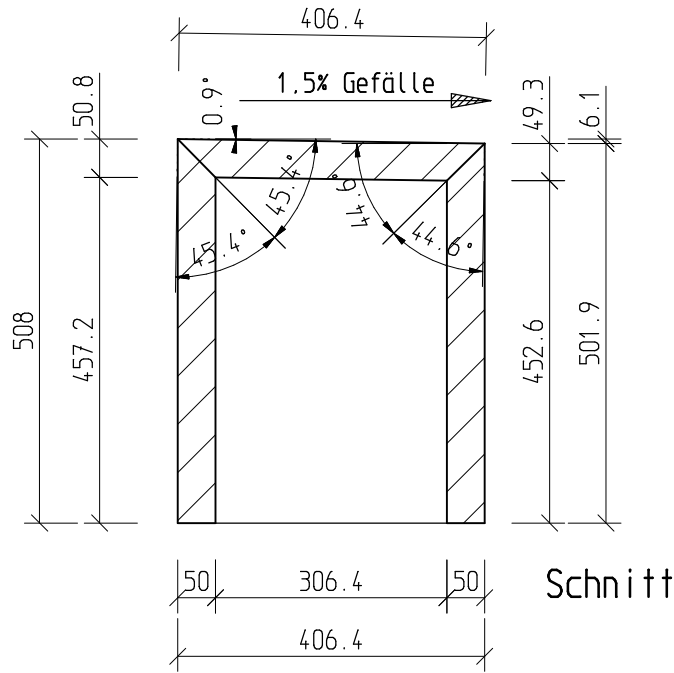

Diese Zeichnung/Skizze ist Eigentum der wedi GmbH und unterliegt dem Urheberrecht. Die Verwendung bedarf in jedem Fall der vorherigen, schriftlichen Zustimmung der wedi GmbH.

Dateiname Filename				Z 00 00 22 84		Benennung/Designation		wedi US Bench aus Bauplatte BA50					
Kunde: wedi USA				BV : ---		<b>wedi GmbH</b> Hollefeldstrasse 42 48282 Emsdetten wedi Sanoasa Tel. 02572/156-442 Fax 02572/156-239		Maßstab Scale 1:10					
				Datum Date						Name Name			
				Bearb. Drawn						24.01.06		Voßkamp	
				Gepr. Checked									
				Norm Approved									
				Fertigzustand/Bautoleranz: finished condition/tolerances:		Rohstoff/Raw material Rohteil-Nr./Raw piece No.		Werkzeug-Nr./Tool No.					
A				Gefälle		20.02.08		VO					
Ausg. Issue				Änderung Modification		Datum Date		Name Name					
				Maße in mm Dimensions in millimeters		Ursprung Source		MegaCAD evolution II					